

HECKLER

Heckler Bearing Overhaul Instructions

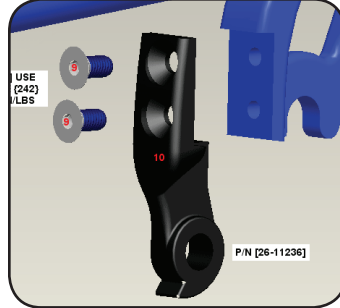

Click To Enlarge



Click To Enlarge

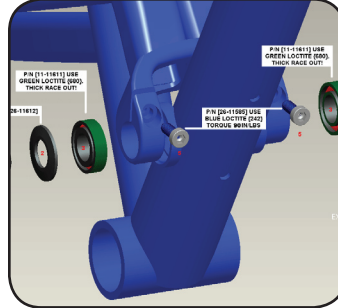

Click To Enlarge

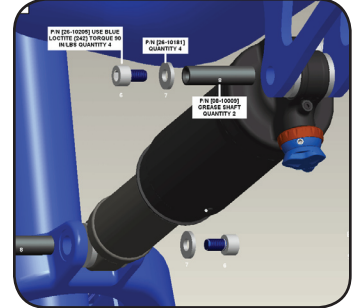

Click To Enlarge

Superlight (new 2006), Heckler (new 2007) and Juliana (new 2006) Bearing Overhaul Instructions
(These instructions work for all three models. The frame pictured is a Superlight (new 2006))

Tools Required:

- 3/4" Wrench
- 7/8" Wrench
- 7902 Bearing Press/Removal Tool Kit
- Allen Wrench Set (3-8mm)
- Mallet
- Loctite 680 (green)
- Loctite 242 (blue)
- Grease
- Q-Tip
- Isopropyl Alcohol

The Heckler Propack Includes:

- 7902 Bearings (2)
- Bearing Dust Caps (2)
- M6x22mm Pinch Bolts (2)
- M6 Washers for Pinch Bolts (2)
- Pivot Axle
- Pivot Axle Cap
- M8x40 Shock Bolts (2)
- M8 Washers (2)
- Sample Pack Loctite 680.

The Superlight Propack Includes:

- 7902 Bearings (2)
- Bearing Dust Caps (2)
- M6x14mm Pinch Bolts (2)
- Pivot Axle
- Pivot Axle Cap
- Shock Axles (2)
- M5 Shock Axle Bolts (4)
- M5 Shock Axle Washers (4)
- Sample Pack Loctite 680

The Heckler Bearing Pack Includes:

- 7902 Bearings (2)
- Bearing Dust Caps (2)
- M6x22mm Pinch Bolts (2)
- M6 Washers for Pinch Bolts (2)
- Sample Pack Loctite 680

The Superlight Bearing Pack Includes:

- 7902 Bearings (2)
- Bearing Dust Caps (2)
- M6x14mm Pinch Bolts(2)
- Sample Pack Loctite 680

Step 1: Read the instructions!

It's the right thing to do, so just go ahead and do it. Understand what you are about to encounter. Remove your rear wheel and crankset. Clean off the major dirt so you don't contaminate grease or Loctite later on.

Step 2: Remove the Shock

Heckler: Use a 6mm allen wrench to remove both shock bolts. Take care not to lose the small washers unless you are installing a propack.

Superlight: Grab your 4mm allen wrenches. Turn the front shock axle bolts counterclockwise until one of the bolts comes out. Re-install the removed bolt 4-5 threads without its washer, and tap it until it bottoms on the frame. Remove this bolt, and continue tapping the shaft out using a punch, 6mm allen, or long M5 bolt. Place a rag between the front of your shock and the downtube to avoid scratching the paint. Repeat for rear shock axle. (Fig. 1)



Fig. 1

Step 3: Separate Front Triangle and Swingarm

- a) Using a 5mm allen wrench, remove both pivot pinch bolts.
- b) Hold the pivot axle in place with an 8mm allen wrench, and loosen the pivot cap with a 5mm allen.
- c) When the cap is loosened 3-4 threads, give it a tap with your mallet to break the axle loose. Remove pivot cap.
- d) Push axle out of frame, using a punch or allen wrench and mallet to tap out if necessary.
- e) Remove swingarm from front triangle and pull off bearing dust caps.(Fig. 2)



Fig. 2

Step 4: Remove Bearings

- a) Slide bearing removal tool through bearings solid end first. (Fig. 3)



Fig. 3

- b) Tap tool lightly until the tines snap into place behind one bearing. Tap with mallet until the bearing pops out. (Fig. 4)
- c) Repeat for other bearing.



Fig. 4

Step 5: Prep for Re-Assembly

Clean the pivot axles and scrape off dried Loctite from the bolts. Coat all of the pivot axles with Rock and Roll Super Coat Grease, or another high quality, sticky, slick grease. Scrape dirt and dried Loctite from bearing bores, then clean with alcohol.

Step 6: Install New Bearings

- Clean bearings with isopropyl alcohol and spread Loctite 680 around the bearing bores. (Fig. 5)
- Important: Install bearings onto the press tool so that the black seal will face out when installed.



Fig. 5

- Assemble tool as shown, and press bearings into frame simultaneously using the 3/4" and 7/8" wrenches. Stop immediately if one of the bearings goes in crooked. The bearings should bottom in bore. (Fig. 6)



Fig. 6

Step 7: Assemble Main Pivot

- Apply grease to the concave surface of the bearing dust caps so they will stick to the bearings. Apply them to the bearings concave side in. (Fig. 7)
- Grease the external surface of the pivot axle, and install through swingarm and bearings from the drive side.



Fig. 7

- c) Apply Loctite 242 to pivot cap threads and tighten to 70 in/lbs. (Fig. 8)
- d) Heckler: Apply Loctite 242 to M6 pinch bolts and install with the M6 washers. Torque to 125 in/lbs.
Superlight: Apply Loctite 242 to M6 pinch bolts and tighten to 90 in/lbs.
- e) Check swingarm for smooth movement and ensure there is no side to side movement.

Step 8: Install Shock

- a) Heckler: apply loctite 242 to shock bolts and install with washers.
Superlight: Grease external surface of shock axles and install.
 - b) Heckler: Torque to 145 in/lbs.
Superlight: Apply Loctite 242 to all shock axle bolts and torque to 90 in/lbs.
- Now install your crankset and go ride!



Fig. 8

Bonus: Derailleur Hanger Replacement

- a) Use a good fresh 3mm allen wrench and remove both bolts.
- b) Apply Loctite 242 to bolts and install new dropout. Hold hanger straight while you torque the bolts to 80 in/lbs.
- c) Check hanger alignment using a derailleur Hanger Alignment tool, align if necessary. (Fig. 9)



Fig. 9